



OUTDOORSINESS

BE THE DESTINATION

6' Downtown Bench with Back

Models:

BDT06-G-55-000

BDT06-H-55-000

BDT06-I-55-000



Parts, Hardware, and Suggested Tools

Unit Common Description	Units Per Model
6' Downtown Bench Seat with Back	1
Frame	2
Connecting Pipe	1
3/8" x 1-1/2" Button Head Bolts	4
3/8" x 2" Button Head bolts	2
Allen wrench	1

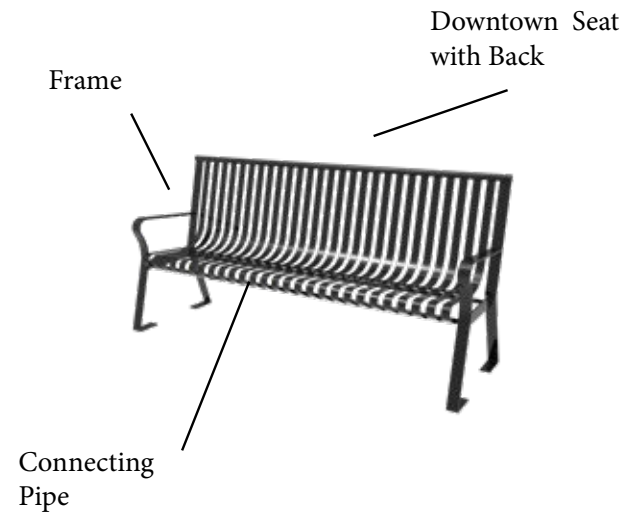

Specification - Written

Seat Material: 11 gauge Strap Metal.

Seat Coating:

- Advantage Coating - MyTCoat's Advantage Coating is our proprietary coating unique only to MyTCoat. This state-of-the-art coating will not chip, crack or peel. It doesn't have any drips or runs, and it's the most durable coating on the market. The Advantage coating comes with a 7 year Warranty and is available in 13 Different Colors.
- Industry Standard Coating - the Industry Standard line is coated with a Premium Polyethylene Coating, The Industry Standard coating comes with a 5 year warranty and is available in 9 different colors
- Powder Coat Finish - Premium High Quality Powder Coat Finish Electrostatically Applied with 13 Different Colors to choose from.

Frames: 2" x 3/8" Formed Steel

Frame Coating: High Durability Architectural Grade electrostatic applied Powder Coat.

Hardware: Stainless Steel

Dimension: 46" Pedestal Picnic Table Top - 46" W x 46" L, Seats - 10" W x 38" L, Overall Dimension: 81.6" W x 81.6" L x 30" H

Specification - Drawing

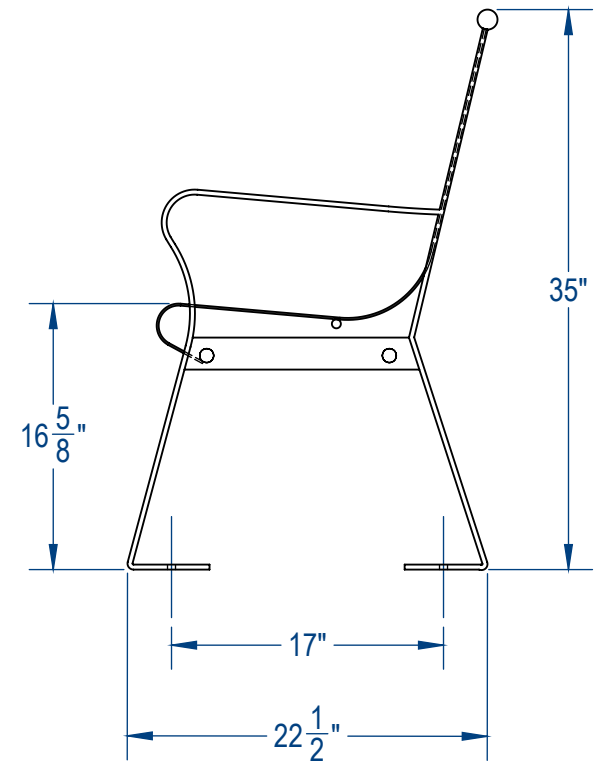
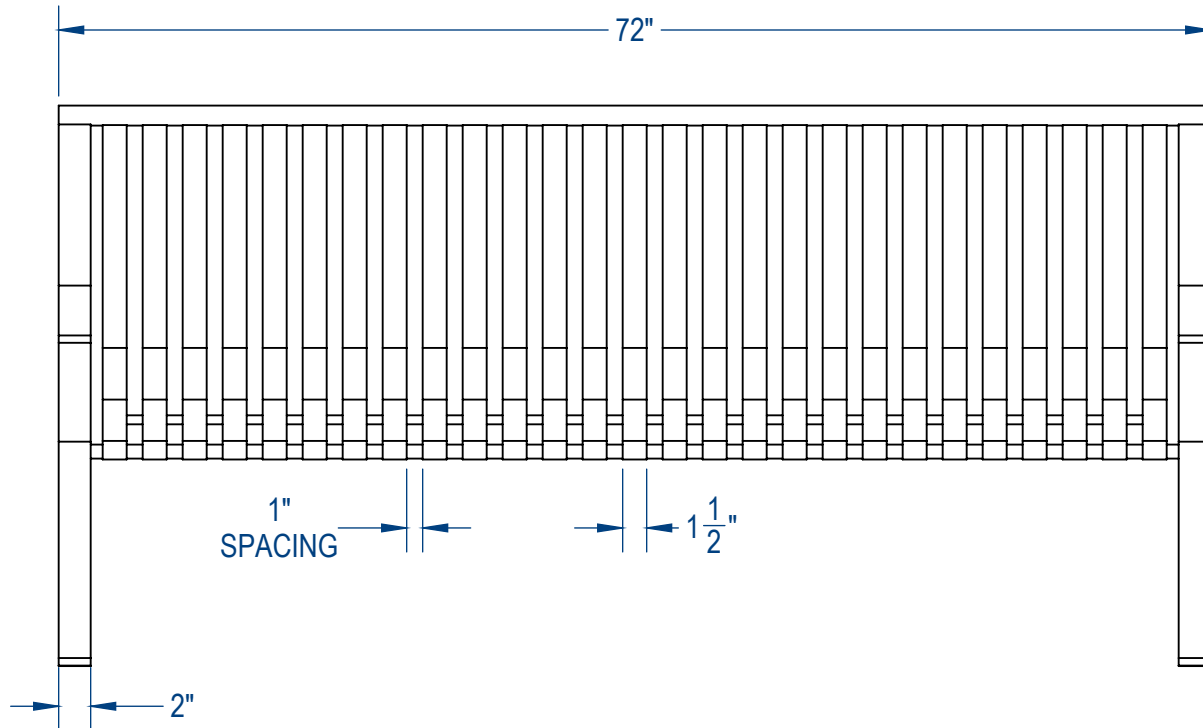

Assembly Instructions

MyTCoat does not offer installation: Recommend a professional Installer to install this Bench.

- 1. Bolt frames to both sides of the bottom portion of the seat with the 3/8" x 1-1/2" Bolts. Hand tighten at this time**
- 2. Line up bolt holes of the top portion of the bench with the bolt hole at the top of the frame, bolt together with the 3/8" x 1-1/2" Bolts. Hand tighten at this time**
- 3. Insert the Connecting pipe behind the bench seat at the bottom of the seat and align with bolt holes on frame. bolt together with the 3/8" x 2" bolts and tighten.**
- 4. Go back and tighten the other 4 bolts.**

Installation Safety:

Please Follow Installation Instructions provided by Manufacturer

It is recommended that Product is installer by an experienced installer

Product should be inspected at the time of Delivery, do not install and damaged on defective parts or products.

All Hardware for proper assembly (not installation) is provided. Use hardware that is included with this product.

Product Maintenance:

Maintenance inspection should be performed at a minimum of once a year.

Cleaning, when necessary can be performed with warm water and most household cleaners, avoid any harsh chemicals such as paint remover and acetone. Contact Manufacturer before cleaning to determine if cleaning product is OK for use.

Any surface rust that may occur should be removed and repainted. Contact Manufacturer for touch up paint or any other recommended paints.

Contact Manufacturer for instructions on removing vandalism such as spray paint.

In the case that the MyTCoat coating is damaged, contact Manufacturer for instructions for repair.

Bolts and nuts should be checked on a regular basis to maintain proper tightness.