



OUTDOORSINESS

BE THE DESTINATION

6' Bench without Back - Rolled Edges - Surface Mount

Models:

- BRE06-A-23-000
- BRE06-B-23-000
- BRE06-C-23-000
- BRE06-D-23-000



Parts, Hardware, and Suggested Tools

Unit Common Description	Units Per Model
Surface Mount Bench Frame	2
5/16-18 x 1 1/2" tap bolt w/black xylan	4
5/16-18 nylock nut w/black xylan	4
5/16 uss flat washer w/black ox	8
#vc300-8 5/16" bolt size 1/2" lg vinyl cap	4
6' Rolled Edge Seat Expanded Metal or Punched Steel (Depending on model ordered)	1

Suggested Tools



Open Face Wrench



Socket Wrench



Tape Measure



Level

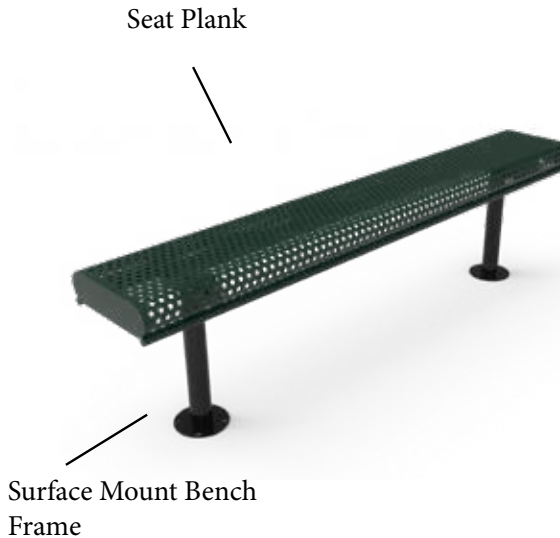

-  Bolt (HW01)
-  Nut (HW02)
-  Washer (HW03)
-  Bolt Cap (HW04)

Specification - Written

Seat Material: Outer frame is made from 11 gauge Steel

- Expanded Metal models - Inside material is 3/4" #9 Expanded Metal, Bracing is 1-1/2" Solid Steel flat bar. All MIG welded.
- Punched Steel models- Inside material is 12 gauge, 1/2" punched Steel. Bracing is 1-1/2" Solid Steel flat bar. All MIG welded.

Seat Coating:

- Advantage Coating - MyTCoat's Advantage Coating is our proprietary coating unique only to MyTCoat. This state-of-the art coating will not chip, crack or peel. It doesn't have any drips or runs, and it the most durable coating on the market. The Advantage coating come with a 7 year Warranty and is available in 13 Different Colors.
- Industry Standard Coating - the Industry Standard line is coated with a Premium Polyethylene Coating, The Industry Standard coating comes with a 5 year warranty and is available in 9 different colors

Frames: Frames are made from 2-3/8" OD pre-galvanized steel tubing.

Frame Coating: High Durability Architectural Grade electrostatic applied Powder Coat.

Hardware: All hardware is Xylan coating black hardware for extra protection and strength

Dimension: 6' Surface Mount Bench with Back Overall Dimension: 72" L, Seat Height 18". Seat Width 12.5"

Specification - Drawing

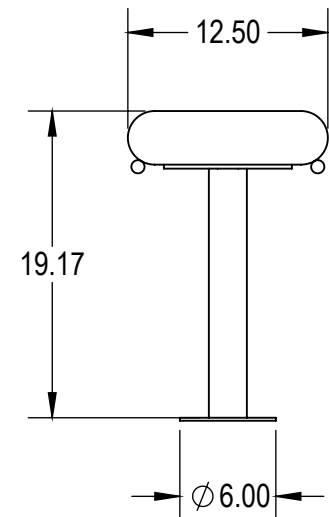
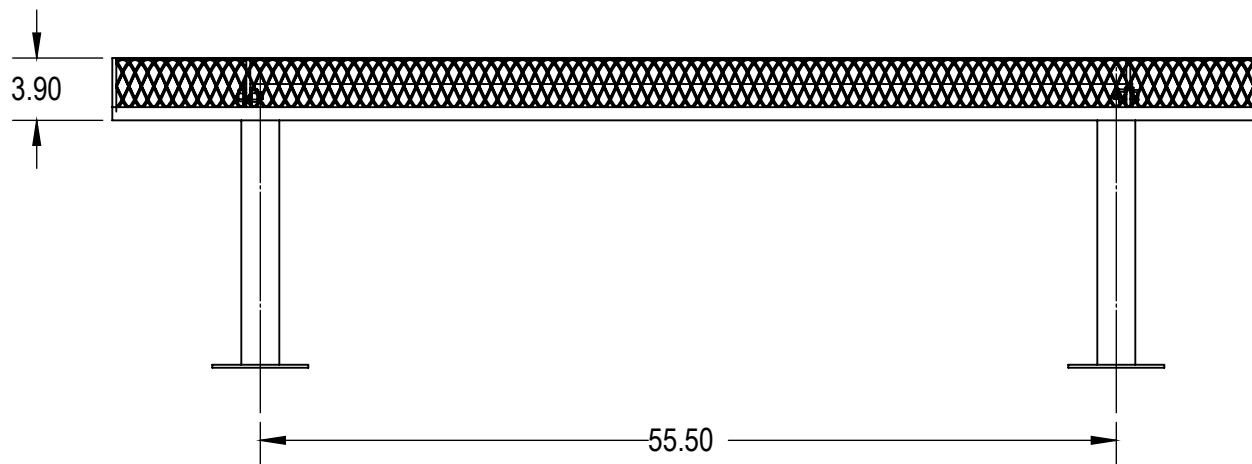
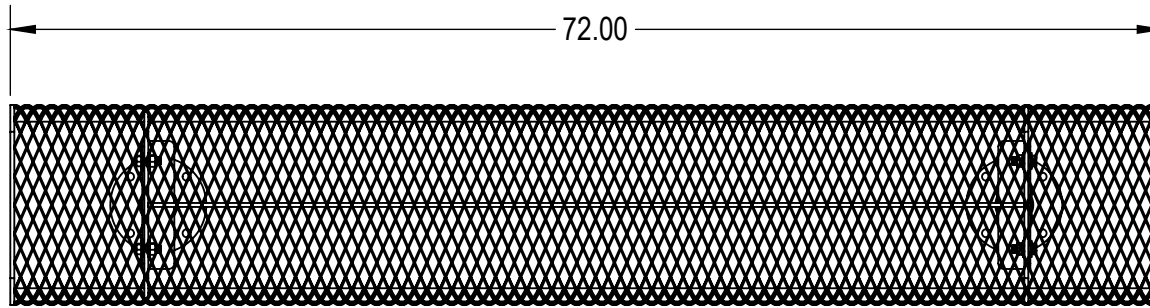

Assembly Instructions

1. Attach Seat Plank to Surface Mount Bench Frame using Hardware Provided. (Hand tighten at this time)

2. Level seat and back and tighten bolts

3. Mount Bench to concrete using concrete anchor bolts. (3" x 5/8" redhead concrete anchor bolts recommended)

MyTCoat does not offer installation: Recommend a professional Installer to install bench inground

Installation Safety:

Please Follow Installation Instructions provided by Manufacturer

It is recommended that Product is installer by an experienced installer

Product should be inspected at the time of Delivery, do not install and damaged on defective parts or products.

All Hardware for proper assembly (not installation) is provided. Use hardware that is included with this product.

Product Maintenance:

Maintenance inspection should be performed at a minimum of once a year.

Cleaning, when necessary can be performed with warm water and most household cleaners, avoid any harsh chemicals such as paint remover and acetone. Contact Manufacturer before cleaning to determine if cleaning product is OK for use.

Any surface rust that may occur should be removed and repainted. Contact Manufacturer for touch up paint or any other recommended paints.

Contact Manufacturer for instructions on removing vandalism such as spray paint.

In the case that the MyTCoat coating is damaged, contact Manufacturer for instructions for repair.

Bolts and nuts should be checked on a regular basis to maintain proper tightness.